

QUICKCHECK™ QC2 EM

QuickCheck™ is an intuitive and easy to use patron self-checkout station. The system has a touch screen monitor and offers step-by-step instructions to guide patrons through the checkout process of all library materials including CDs, DVDs, and magnetic media.

The QC2 EM QuickCheck™ works with traditional barcode labels and desensitizes electromagnetic (EM) security tags. The system can also be easily upgraded to process RFID tags. QuickCheck™ is compatible with any Integrated Library System (ILS).

Sidekick™, the remote administration software packaged with QuickCheck™, monitors the performance of single or multiple stations at one or more branches, and can remotely access log files, make configuration changes, update software, and generate statistical reports on self-checkout usage.

FEATURES AND OPTIONS

- Checkout/Check-in/Renewal
- Multiple Languages Included
- Print or E-mail Receipts
- Remote Monitoring, Administration, and Statistical Reporting
- Fines and Fees Payment (credit/debit)
- Integrated Media Unlocker (CD/DVD/etc.)
- Multiple Item Detection
- Web-based Customer Service
- Custom Furniture and Finishes



The QuickCheck™ Model QC2 – EM processes library materials via barcodes and deactivates electromagnetic (EM) security tags. The QC2 accommodates a wide range of barcode placements and deactivates all industry standard EM security tags.

QC2 systems have a modular design, which allows them to be easily upgraded to process RFID tags or to incorporate additional security features, such as the ability to unlock secure AV cases and to detect multiple items.

During the self-check transaction, the system reads the barcode on the collection item, communicates with the Integrated Library System to authorize and record the checkout or renewal, deactivates the EM security tag, and then prints a receipt that informs the patron when the materials are due back to the library. The patron then safely exits the library through the EM detection gates without any intervention from library staff, leaving them free to perform other tasks.

All QuickCheck™ systems employ an intuitive, user-friendly touchscreen interface that provides exceptionally clear and simple instructions to patrons to ensure an enjoyable and successful self-check experience. Virtually every aspect of the QuickCheck™ user interface can easily be customized by library staff to suit the specific needs of the library.

QuickCheck™ is available in Kiosk, Desktop, and Built-in configurations.

Sentry Custom Security | Tel. 1-800-461-2803 | Fax. 1-416-674-5075
sentrycustom.com | sales@sentrycustom.com

SENTRY
CUSTOM SECURITY

QUICKCHECK™ CONFIGURATIONS

QUICKCHECK™ KIOSK

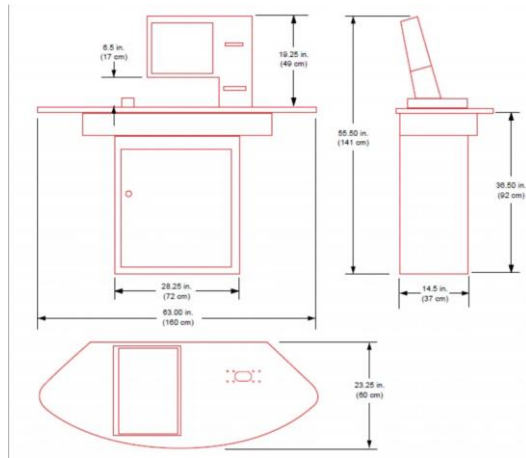

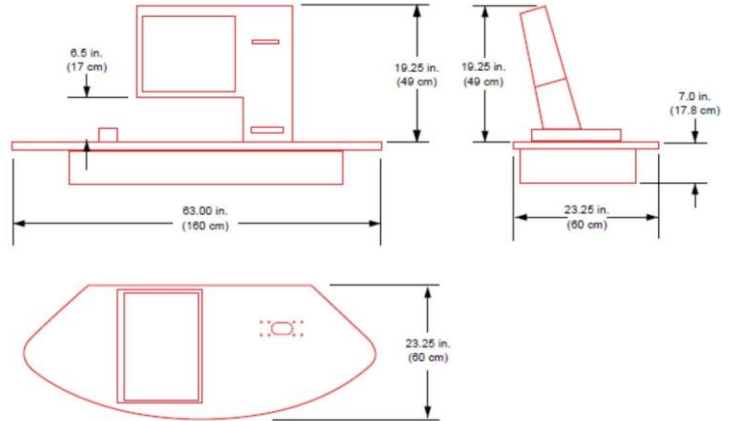

QUICKCHECK™ DESKTOP

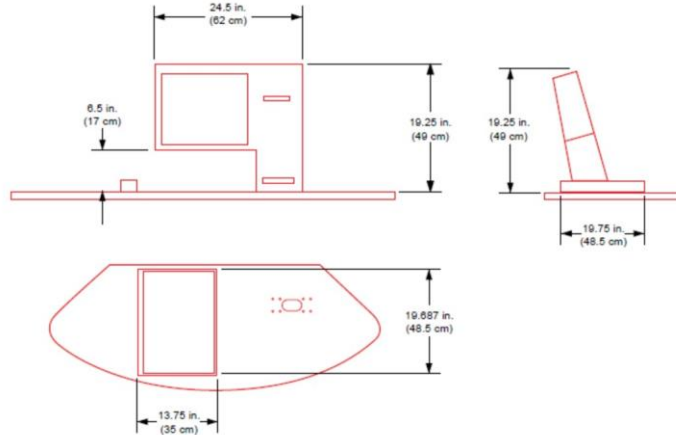

QUICKCHECK™ BUILT-IN



QUICKCHECK™ FEATURES

- ✓ Easy check-outs, renewals, and check-ins
- ✓ Processes every kind of collection item, including CDs and DVDs
- ✓ User interface available in 13 different languages at no additional cost:
 - English, Spanish, French, Portuguese, Russian, Slovakian, German, Italian, Punjabi, Creole, Chinese Traditional, Chinese Simplified, Vietnamese
 - Additional languages can be purchased
 - Language of the user interface can be changed at any point in the check-out process
- ✓ Patrons can select language of “Date Due” and status receipts
- ✓ Patrons can access account information, such as a list of items checked out, due dates, fines and fees owed, books on-hold, books ready for pick-up, etc.
- ✓ Reduces repetitive strain injuries for library staff
- ✓ Frees library staff to concentrate on other tasks at the library, such as reference questions
- ✓ Compatible with every Integrated Library System, including Innovative Millennium, SirsiDynix, ExLibris, Evergreen, etc.
- ✓ All QuickCheck™ systems include Sidekick™, a remote administration and statistical reporting software package, at no additional cost
- ✓ User interface can be completely customized. Library staff can easily alter colors, fonts, text, layout, pictures, and sounds according to your preferences
- ✓ Standard finishes:
 - Cabinet 
 - Countertop 
- For an additional cost, hundreds of custom finishes are available to suit any library’s décor
- ✓ All QuickCheck™ systems feature a modular design that can very easily be upgraded to RFID without the need to purchase an entirely new system